

READ THROUGH ALL THE INSTRUCTIONS BEFORE YOU START.

To construct this kit you will need the following:

1. A Modellers knife.
2. A pair of sharp pointed scissors.
3. A steel ruler.
4. Glue - UHU Clear Adhesive or Bostik Clear Adhesive are best.
Make sure you get the tubes with the narrow nozzle for easy application.
5. A cutting surface - a sheet of card or a cutting mat.
6. Tweezers to hold the smaller components.

PLEASE NOTE

Each component is fastened to the sheet by means of a score line. These are cut lines that have only gone about three quarters of the way through the card. To detach each component from the sheet, locate the score line that is holding it in place. (most of these are clearly marked with blue arrows) and carefully run the point of your knife along the scoreline and the item will come seamlessly away. CAUTION - be very careful when running the point of your knife along these score lines, it is easy to run out of the groove and cut something you shouldn't.

Your Work Surface

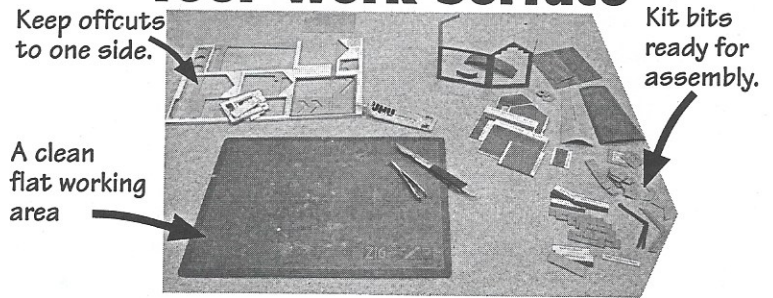

Keep it tidy. When you have extracted all the components from the sheet, place them in neat piles, FACE UP on sheets of thick card, so you can move them around as needed. TAKE CARE WITH SMALL COMPONENTS PLACE MULTIPLES IN PILES TOGETHER. DON'T THROW ANYTHING OUT. Offcuts can come in handy for bracing etc. and it also reduces the risk of accidentally throwing anything away.

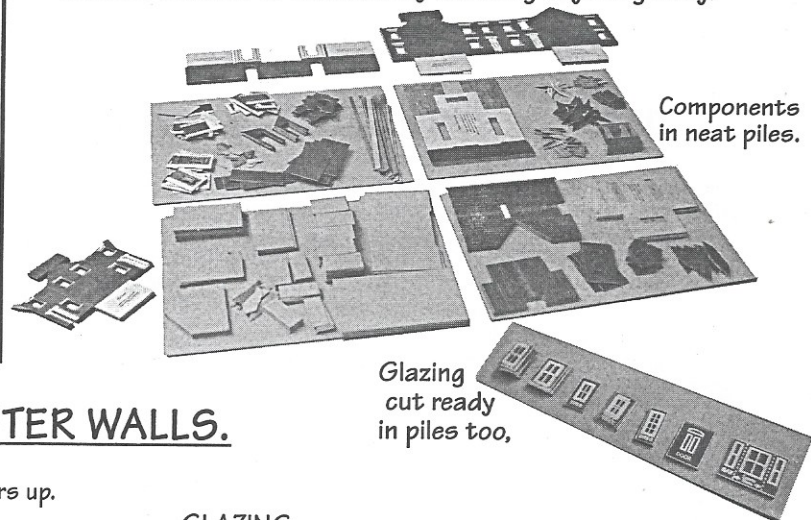
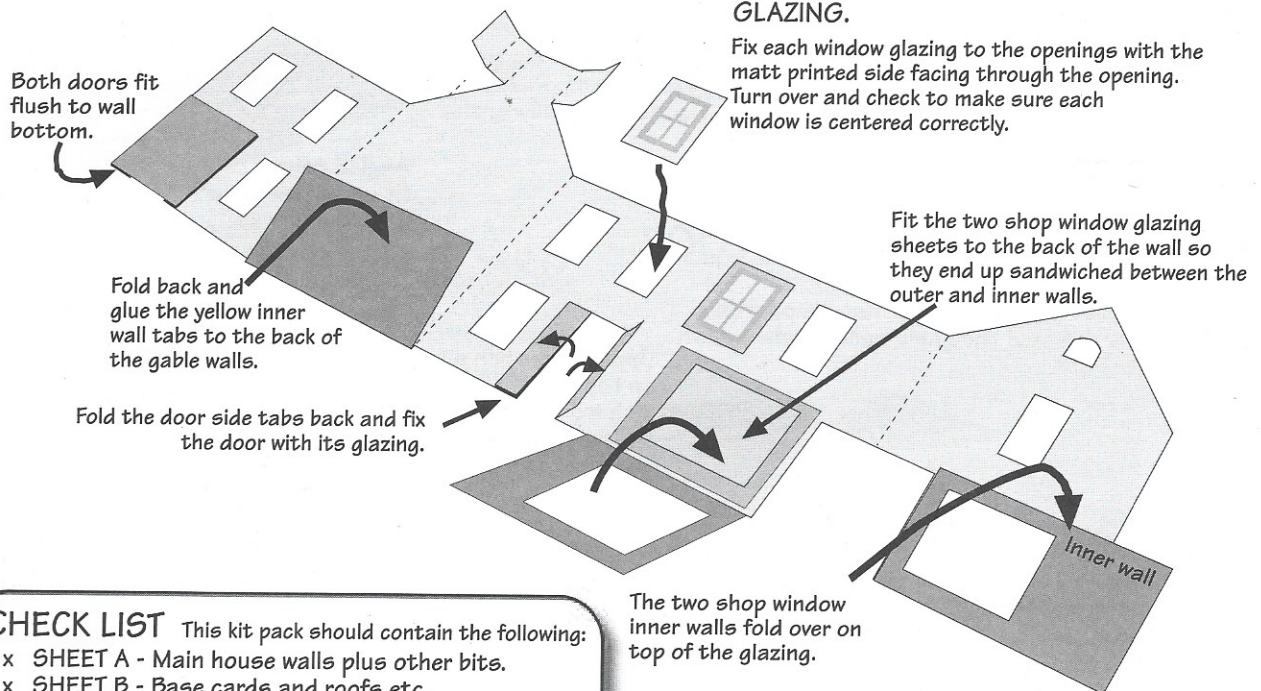

Fig. 1. MAIN BUILDING OUTER WALLS.

Start by folding all scorelines fully to loosen the corners up.



CHECK LIST This kit pack should contain the following:

- 1x SHEET A - Main house walls plus other bits.
- 1x SHEET B - Base cards and roofs etc.
- 1x GREY SHEET - Inner floors and chimney formers.
- 1x Extra bits sheet with curtains and alternative signs.
- 1x GLAZING SHEET.
- 2x SHEETS Self Adhesive Paving
- 2x A3 INSTRUCTION SHEETS
- 1x SILLS & LINTELS SHEET

The two shop window inner walls fold over on top of the glazing.

Fix the curtains as in Fig. 2. then place on one side whilst you make the base card in Fig. 4.

SILLS & LINTELS

There is a laser cut sheet of separate sills and lintels for you to fix to the window and door openings. If you are using them, they are best fitted now whilst the walls are flat. They are a little fiddly to fit but very well worth it.

Fig. 2. CURTAINS.

After you have fitted the glazing, if you require curtains or blinds, now is the time to fit them

To fit curtains fix a small strip of waste card to each side of the window, then glue the curtain to the waste card so that it shows through the window (the waste card will space the curtain back from the window a little giving a greater effect of depth).

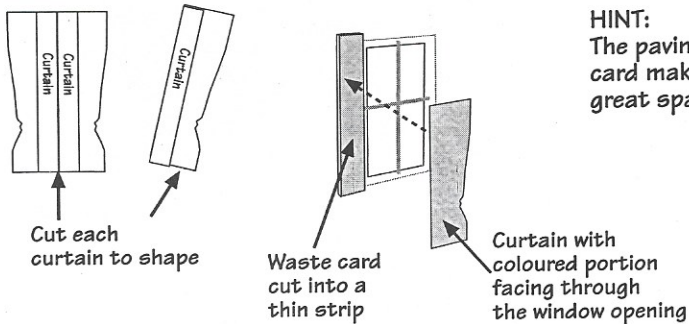

Fig. 3. GREY CARD.

The thick sheet of plain grey card contains the inner strengthening pieces that fit inside the building.

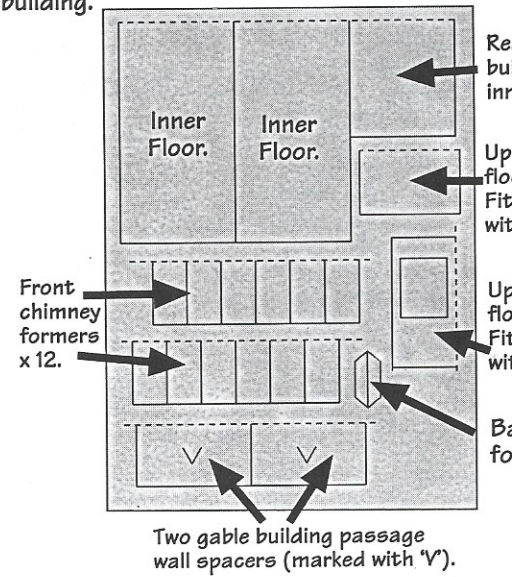

Fig. 5. SHOP WINDOW DISPLAYS.

The window displays have to be built up and fixed in to place on the base card before the building is attached.

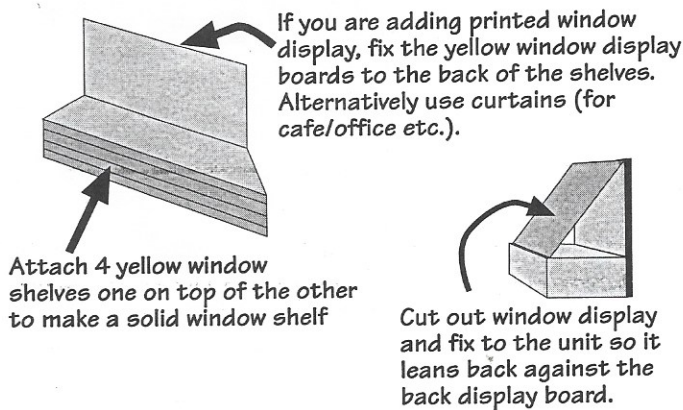

Fig. 6. FIX WINDOW TO BASE

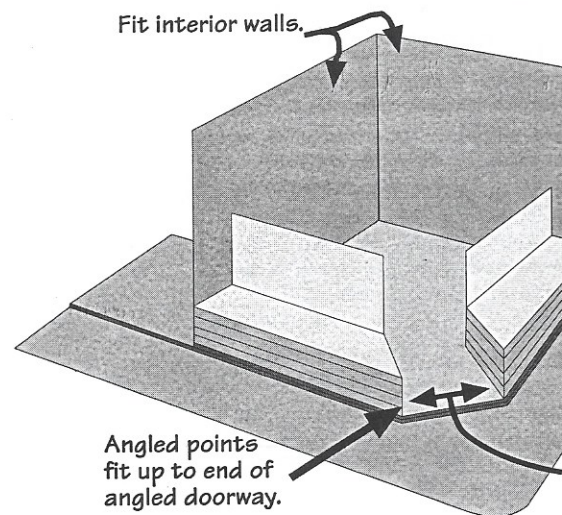

Fig. 8. UPPER INNER FLOOR.

There are two thick grey upper inner floor supports. These fit to the inside of the gable walls, pushed down on to the lower floor.

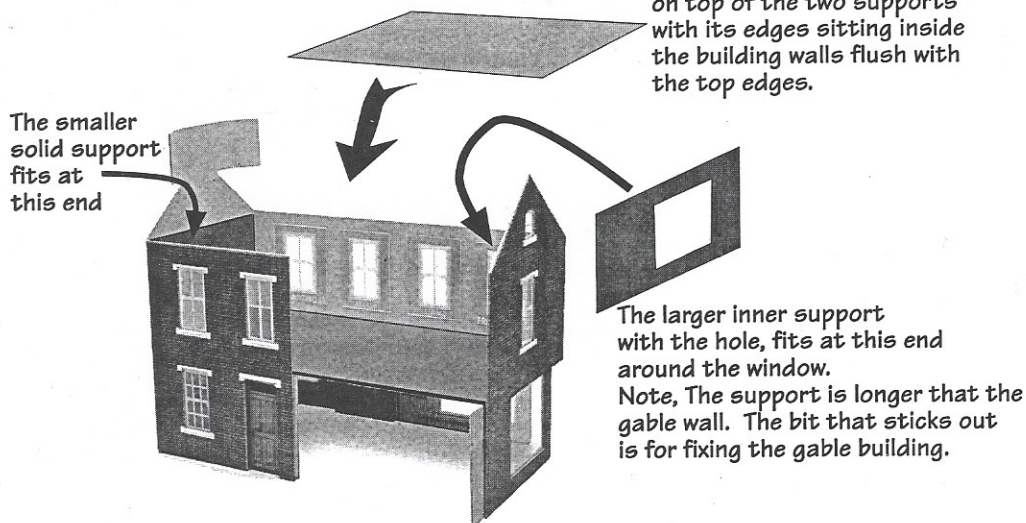
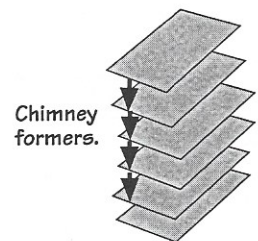

Fig. 9.

Both the chimney stacks together, making sure the chimney stack walls



The separate stack should be made up and put to one side until needed.

Fig. 4. BASE CARDS.

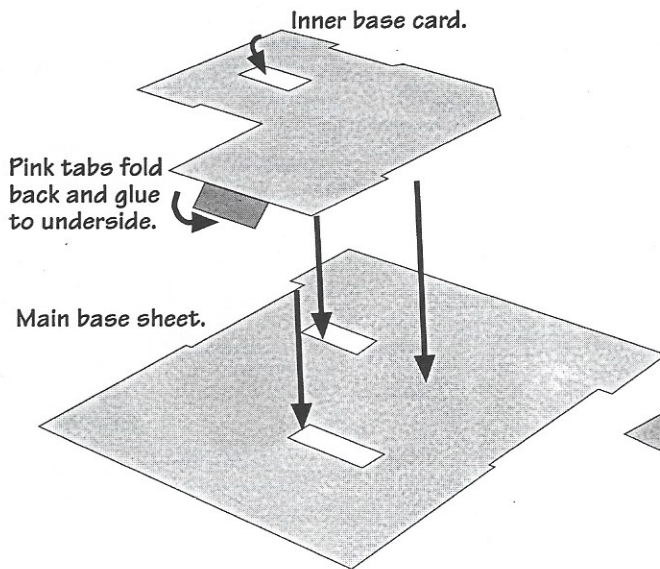

The base section is made of two pieces. The inner card sits on top of the main base sheet.

Start by folding back the two pink tabs on the inner base card. Glue them firmly to the underside. These now act as location tabs that fit into the two holes in the main base card.

Note the recess in this side of the base. This is to accommodate the slightly longer gable wall.

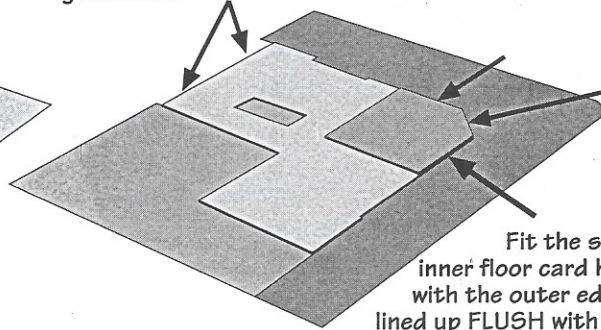

Fit the shop inner floor card here with the outer edges lined up FLUSH with the edges of the inner base card.

WINDOW DISPLAYS CARD.

The two window display units fit on top of the shop inner floor. Fit facing outwards with the edges sitting flush up with the edges of the base card. The angled ends fit in to the doorway.

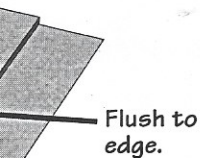

NOW STAND THE BASE CARD UNIT TO ONE SIDE UNTIL NEEDED.

ORWAY

CHIMNEY STACKS.

Build in the same way. Glue 6 chimney former cards they form into a completely rectangular block. Then fold around to form a solid stack.

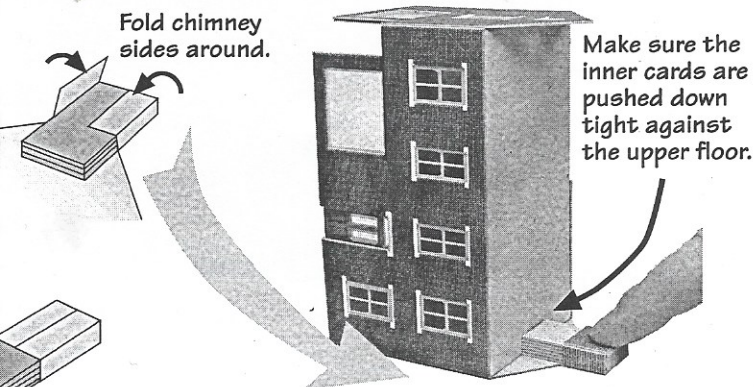
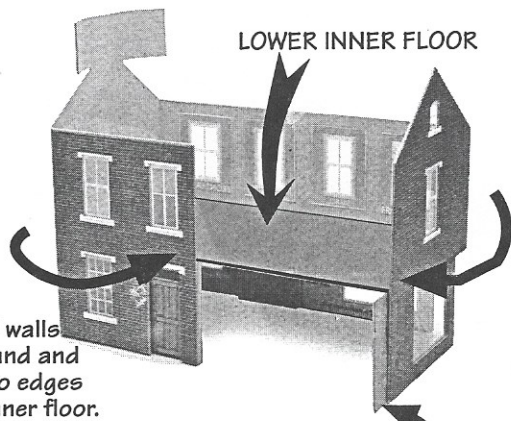

Fig. 7. MAIN BUILDING WALLS.

The walls of the main building section fold around the two thick grey card inner floors.

Start with the lower inner floor, this sits on top of the two yellow inner walls and the door tops. NOTE: It is important that the floor sits firmly down on top of the inner walls etc.



Fold walls around and fix to edges of inner floor.

Note that this inner wall sticks out past the outer wall. This is for fixing the gable building in place at a later stage.

Fig. 10. SO FAR.

This is how the model should look

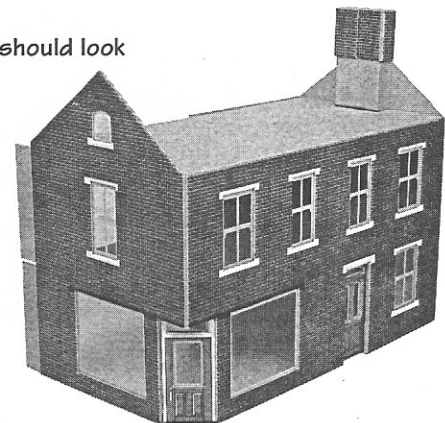

Fit the shop door. Place tiny spots of glue along the edges and slide the door up between the slightly recessed inner walls. Hold walls against door till fast.

Fig. 11. GABLE BUILDING.

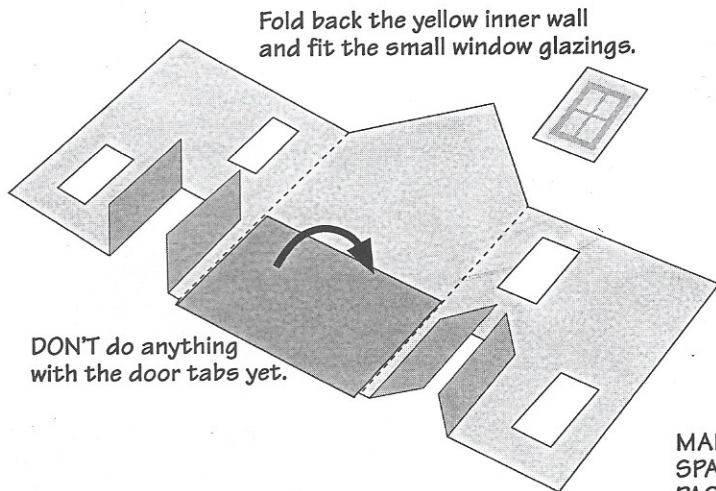

Fig. 13. SIDE WALL.

Fold side walls up and fix the two passage walls on to the inner wall.

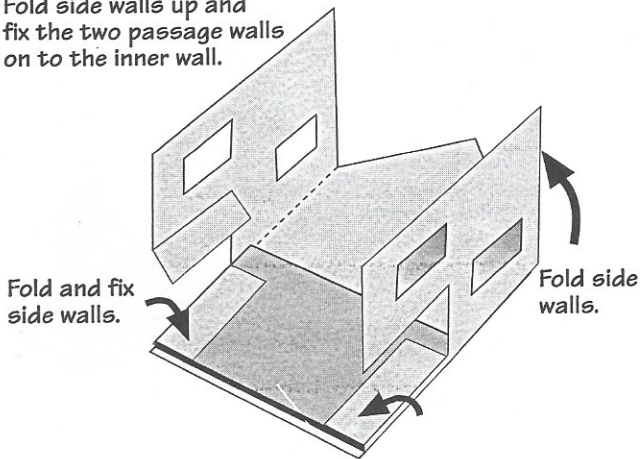

Fig. 15. INNER FLOOR.

The grey inner floor fits inside the building sitting on top of the two passage walls.

If the walls are not quite the same height level the floor so it is not on a slope.

NOW PUT THE GABLE BUILDING TO ONE SIDE.

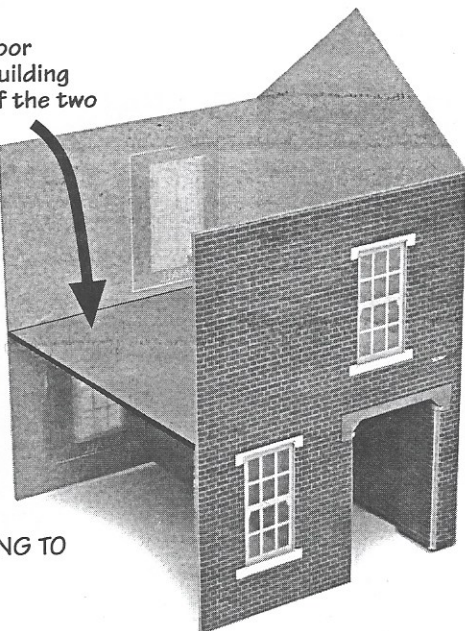
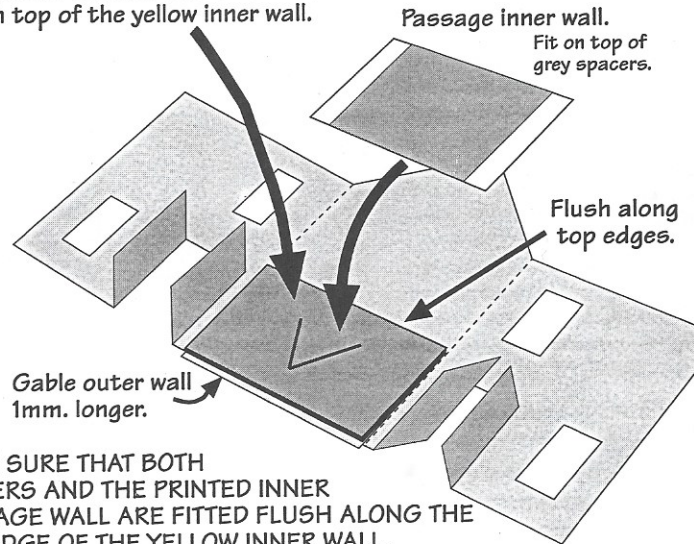

Fig. 12. PASSAGE WALL.

Fix the TWO grey card spacers marked with a 'V' on top of the yellow inner wall.



MAKE SURE THAT BOTH SPACERS AND THE PRINTED INNER PASSAGE WALL ARE FITTED FLUSH ALONG THE TOP EDGE OF THE YELLOW INNER WALL. The gable wall should be 1mm. longer than the inner passage wall.

Fig. 14. FINAL PASSAGE WALL.

Fix the other inner passage wall to the two tabs at the other side of the openings.

Make sure they line up at the base.

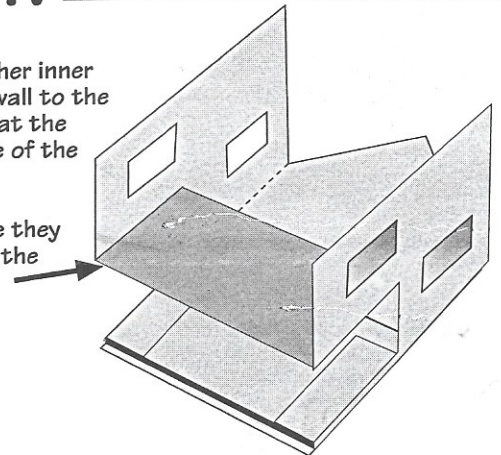

Fig. 16. SHOP WINDOWS.

The two shop window side panels fit around the two shop windows. Fix them so that the top edges are level with the window tops and the sill runs flush with the bottom of the window opening.

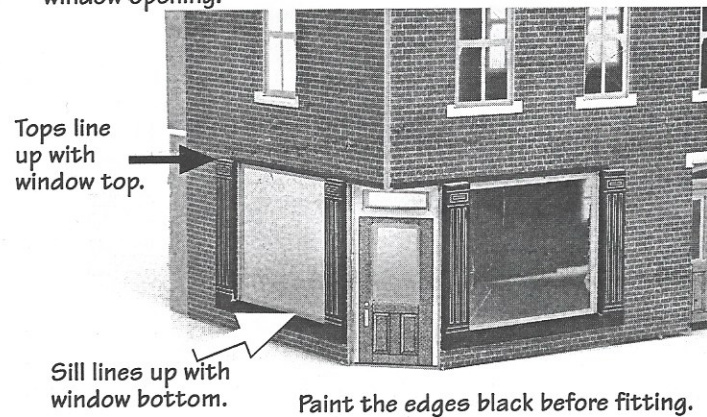
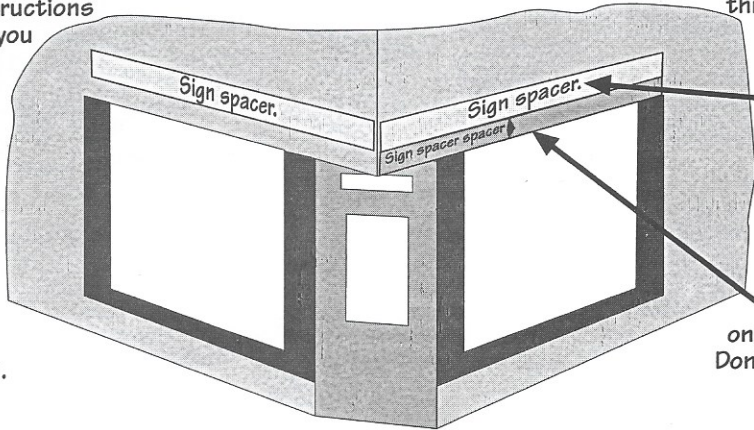

Fig. 17. SHOP SIGN SPACERS.

The signs over the shop window are made of a number of very delicate pieces of card. They are relatively easy to fit, but you must follow these instructions to the letter, or you may make a real mess of the job.

HINT:
Fixing the sign parts is best done with the building laid on its back and end.



Now if you can understand this; The 'Pink spacer, spacer' - spaces the yellow 'Sign spacer' to the correct height above the window. Once the yellow spacers are in position throw the pink spacer away.

Place the yellow 'Sign spacer' on top of the pink spacer. When fast, remove the pink spacer and use to position the other yellow spacer.

Place the pink 'Sign spacer, spacer' strip on top of the window side panels. Don't fix as you need it to come off.

Fig. 18. TOP SECTIONS & SILLS.

There are three L shaped sign board top sections. These sit one on top of the other, on top of the yellow spacer above the windows.

Fit the narrow top section with a white strip on its inside edges. Fit tightly up against the walls and on to the top of the yellow spacers.

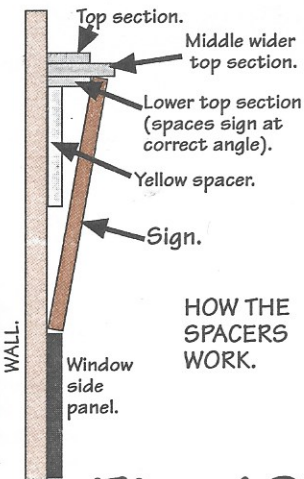

HOW THE SPACERS WORK.

Paint the edges of the sills black, then fit on to the window bottoms.

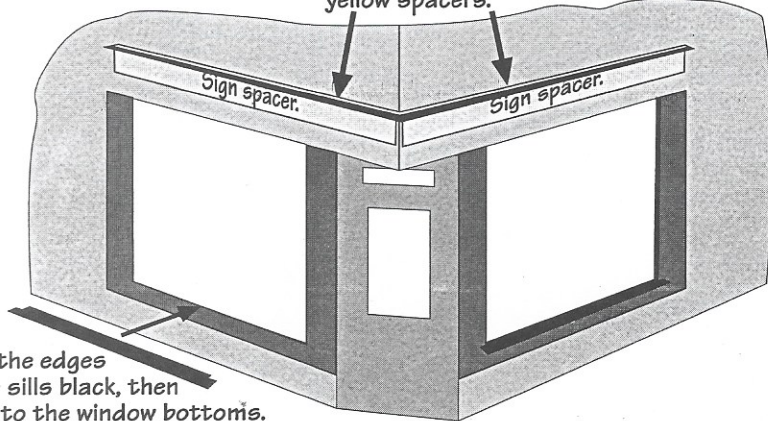

When the lower top section is fast (and not before) Fit the middle wider black section directly on top, and the last narrow black top section.

Fig. 19. SIGN BOARD.

The pre cut signs wrap around the corner of the building fitting above the window sides and on to the spacers so that they lean out at an angle.

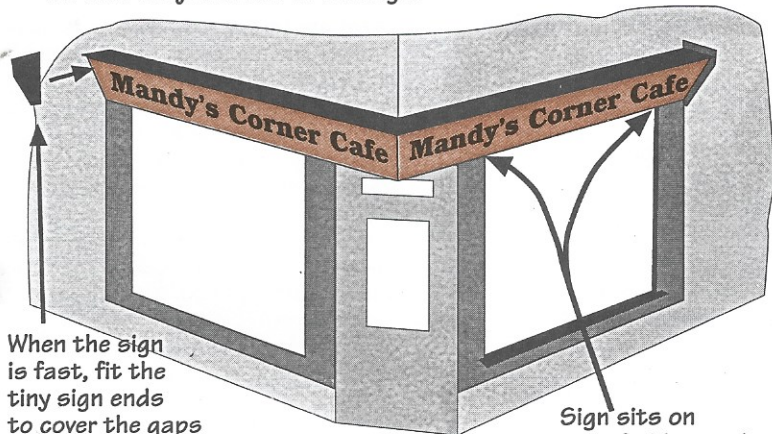
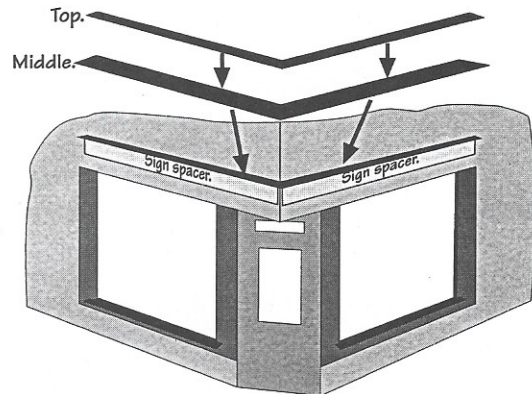

If you can't be bothered with the spacers and tops etc. - simply cut the signs into two rectangles and stick them flat on the walls directly above the windows.

Fig. 20. GABLE BUILDING ROOF SUPPORT.

The yellow roof support needs to be fitted inside the gable building.

Fit far enough inside to allow the tabs on the main building to fit inside

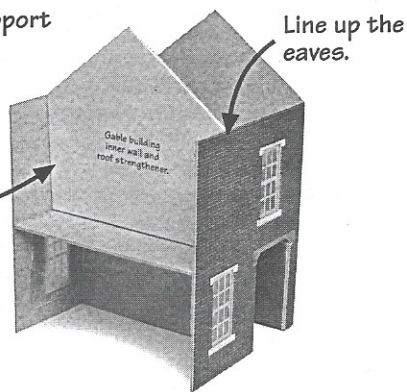

Fig. 21. FIT MAIN BUILDING

The main building sits over the interior with its inside edges fixed up against the inner base card. Note how the gable fits over the edge of the main base card

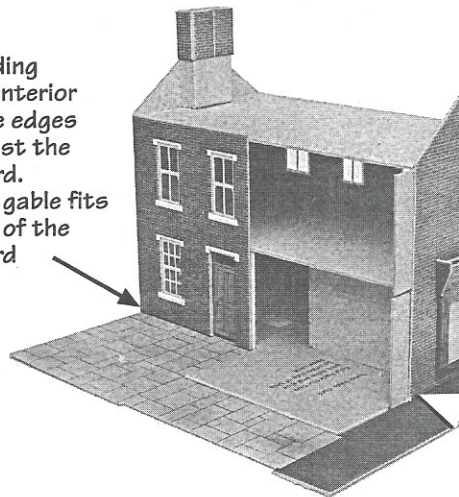
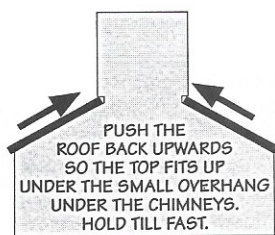
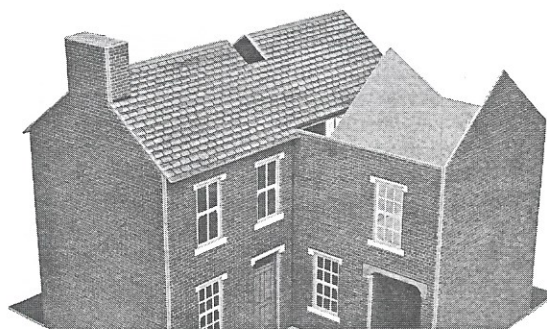

Fig. 23. FIT ROOFS.



Open the roof out and fit up under the chimney.

The roof fits flush to the gable end with the chimney but overhangs past the wall end at the other side.



Push the chimney in to the hole in the roof.

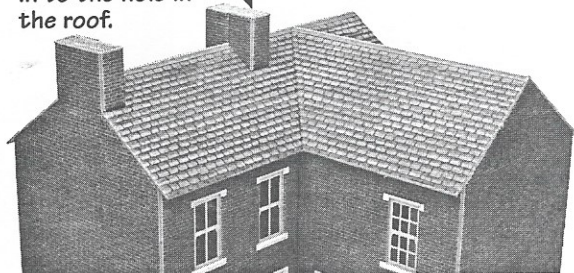

The gable roof sits on top of the main roof. The end of the roof should be flush with the gable wall, but don't worry if it overhangs a little.

Fig.

Fold the g and fix to Leave a gap 1mm at the of the gap

Fig. 26. DORMER WINDOWS.

Inner former.

The dormer windows fold around an inner former card to hold rigid.

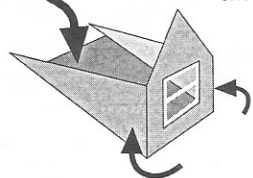

Fit the glazing first.

Make up the dormers and put them to one side until needed. If you are making more than one kit, it's a good idea to make them all at once.

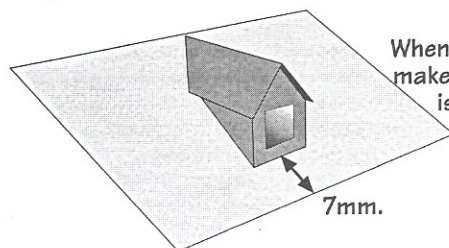
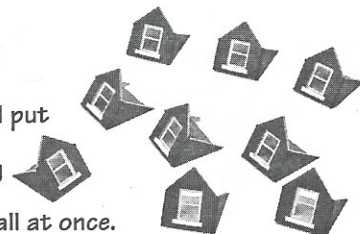

When fitting the dormers make sure the front edge is no more than 7mm from the front edge of the roof.

Fig.

The yard walls sit on with the our so they cov Next sit the the yard an

Fig. 27. PAVING.

There are two sheets of self adhesive paving Peel off the individual slabs from the backing and stick them in place on the brown base a in front of the houses. Start by attaching the thin edging strips, flush along the front edge of the base. Then lay the flags as shown - one full and one half flag on each row.

When you get to the corner in front of the shop door, you will need to do a bit of customising and turning to get them to fit.

NOTE: It is recommended that you place tiny spots of glue under edging strips and slabs for a permanent adhesion.

G TO BASE.

Fig. 22. FIT GABLE BUILDING TO BASE.



Fit the gable building on to the base card, pushed tight up against the main building (IT IS A GOOD IDEA TO FIT WITHOUT GLUE FIRST, SO YOU CAN SEE WHERE IT GOES).

The gable wall fits in to the recess at the back of the base card in the same way as the other gable.

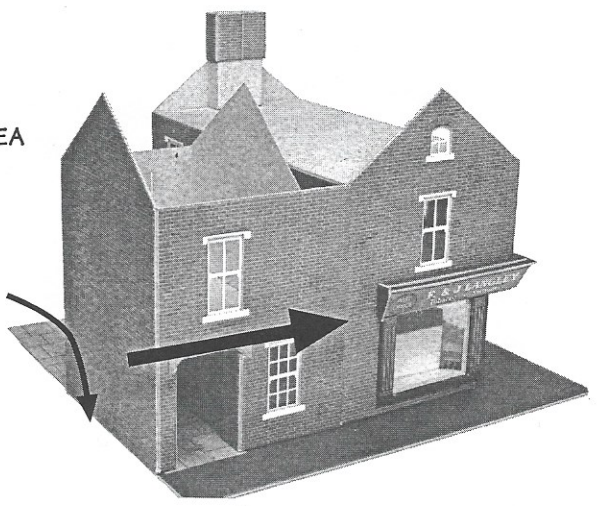

Make sure walls are fixed up against the inner base card.

24. YARD WALLS & SHED.

Make in two the gate opening. Cut up of at least the bottom the

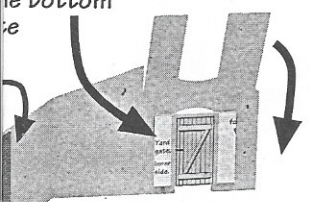

Fold over the two inner bits of the wall. These are 1mm. shorter than the outer wall.

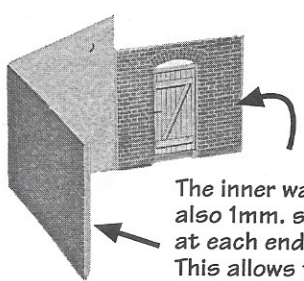

The inner walls are also 1mm. shorter at each end. This allows the overhangs to fit into the corners of the building.

Fit the glazing and door into the shed walls.

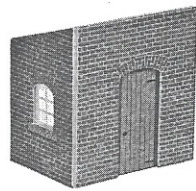

25. FIT WALLS TO BASE.

Make sure the walls fit so that the inner top of the base card is covered by the outer walls overhanging the edges of the base. The shed in the corner of the base should fit its roof.

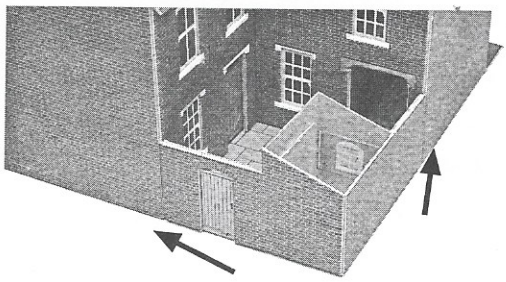

Use the paving slabs in this kit. Lay on a sheet of paving sand.

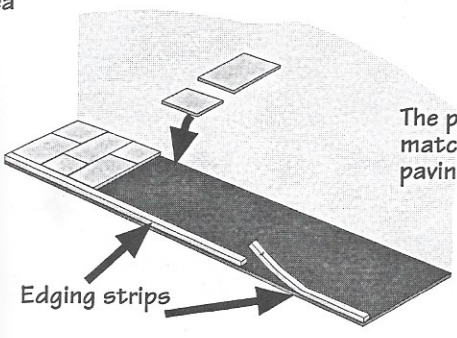

The paving slabs match with our paving pack code no P0210

Fit the door steps when you have finished the paving.

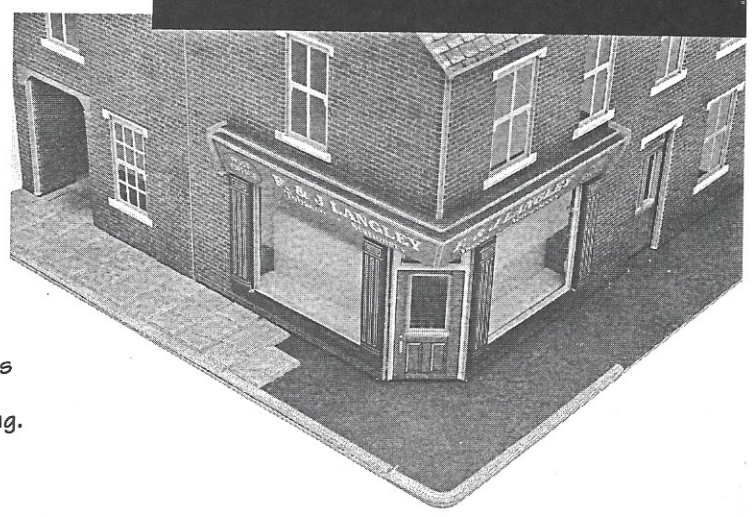
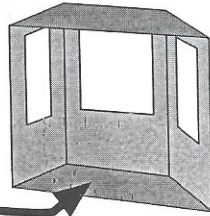

Fig. 28. BAY WINDOWS.

The bay window is an optional extra. To build it start by folding the corners then attach the two grey formers at the top and bottom. Flush to the edges.



Next fit the glazing.

Score along the dotted lines and fold the glazing so that it fits inside the bay window. Fix with tiny spots of glue.

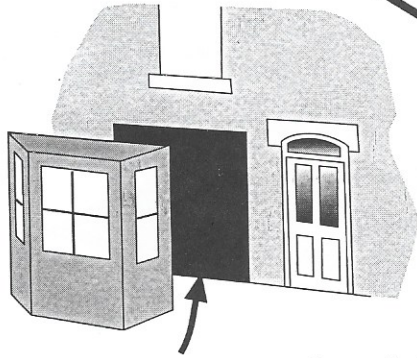
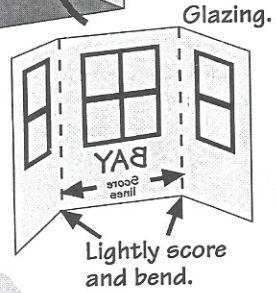
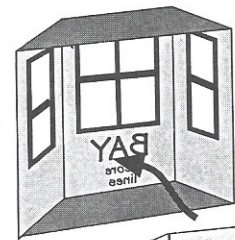

Fix to front of house over front window. Cover the window with black window mask (below).

Fix the small yellow wall plate.

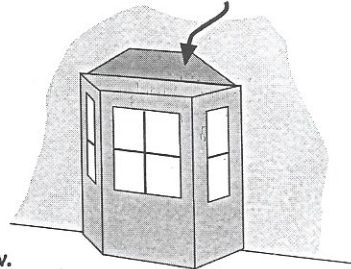

Then fix the bay roof on top.

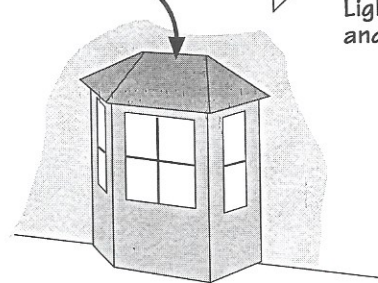

BAY WINDOW MASKS

Use to cover house window when attaching bay window.

See above.

Cut out

FINISHING THE JOB OFF

The ridge tile strips make all the difference to the roof. Cut to length and fold along the centre scorelines, and fit to all the roof ridges with tiny spots of glue dotted along the ridges.



Chimney Pots

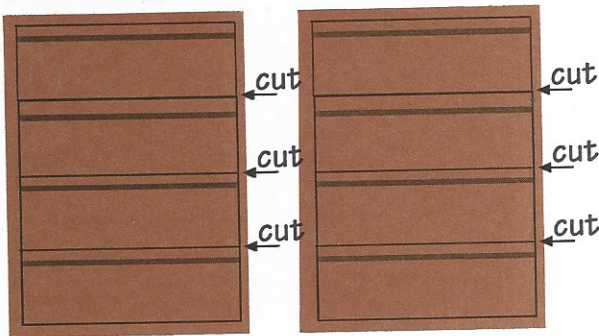

Cut into strips then roll tightly around a nail or screw (apx. 3mm dia.) and fix the end with a tiny spot of glue.

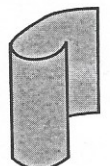

Curl strip slightly first.

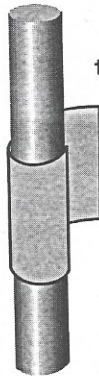

Roll up tight then unroll the end enough to smear with a little glue then roll back up and hold tight until fast.



Finish off by cutting pointed edges with a fine knife or scissors.

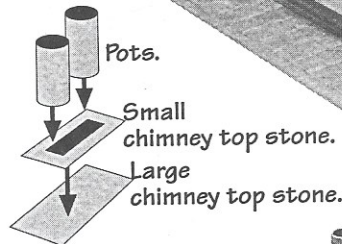

Pots.

Small chimney top stone.

Large chimney top stone.

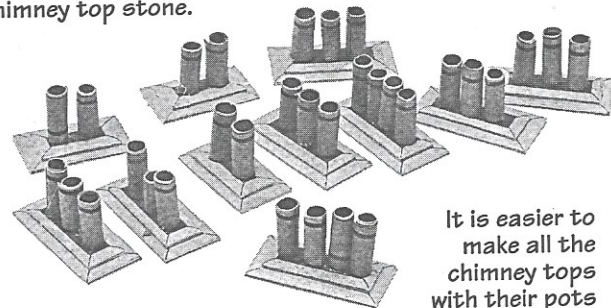

It is easier to make all the chimney tops with their pots beforehand and put them to one side. Fix them after you have done the other jobs on the roof.

PLEASE NOTE - once you have perfected the art of rolling your own chimney pots you will soon realise that they are extremely realistic. Much better than anything made from plastic or white metal. So please be patient & keep trying, the chimney pots make all the difference.